

版本 REV.	日期 DATE	ECN NO.	变更内容 DESCRIPTION	制图 DRAWN

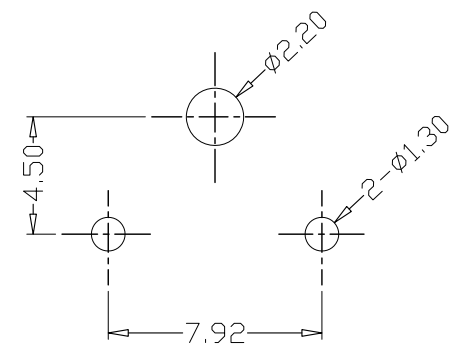

PCB LAYOUT

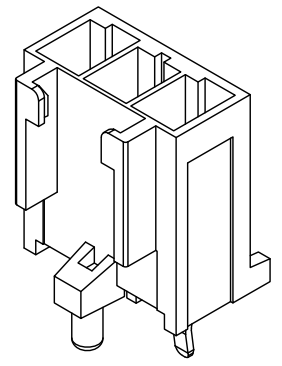
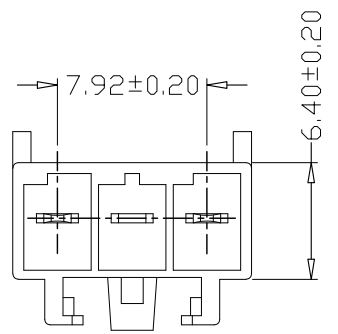
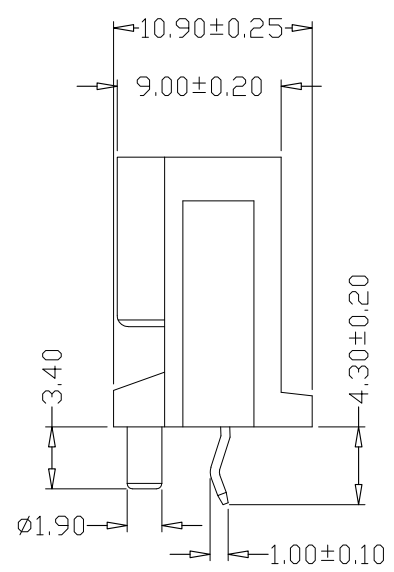
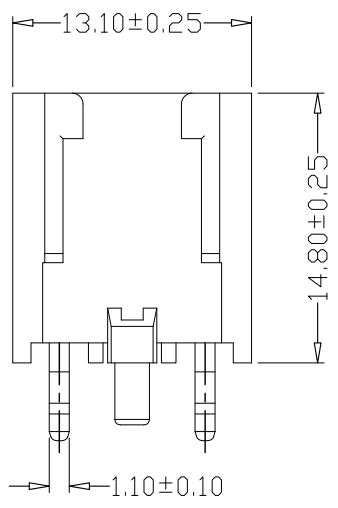

SPECIFICATIONS

- 1、Current Rating: 7A AC, DC
- 2、Voltage Rating: 250V AC, DC
- 3、Temperatuer Range: $-25^{\circ}\text{C} \sim +85^{\circ}\text{C}$
- 4、Contact Resistance: $20\text{m}\Omega$ Max
- 5、Insulation Resistance: $1000\text{M}\Omega$ Min
- 6、Withstanding Voltang: 1000V AC/minute
- 7、Material:
Wafer PA66, UL94V-0
PIN Brass Tin-plated

GENEAL TOLERANCE		制图 Mapping	张迎春 2022、12、21		料号 PART NO.	A79205-3A2T		版本 REV.	A	
X \pm 0.25	X $^{\circ}$ \pm 2 $^{\circ}$	审核 Audit	钱岳生 2022、12、21		品名 TITLE	792001直针 WAFER DIP TYPE		页次 SHEET	1/1	
.X \pm 0.25	.X $^{\circ}$ \pm 1 $^{\circ}$	核准 Approved	张名 2022、12、22		客户料号 CUTM. NO.					
.XX \pm 0.15	.XX $^{\circ}$ \pm 0.5 $^{\circ}$	单位 Units	mm	比例 SCALE						
.XXX \pm 0.10	.XXX $^{\circ}$ \pm 0.5 $^{\circ}$									

乐清市宏一电子有限公司
Yueqing HongYi Electronics Co., Ltd